

Betriebsdruck max. 500 bar.

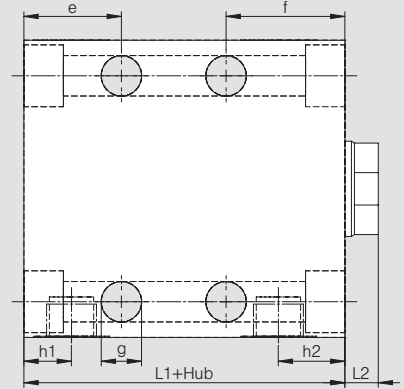
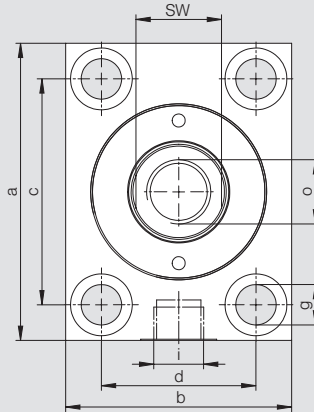

TYP 600

Grundbezeichnung		600-016	600-025	600-032	600-040	600-050	600-063	600-080	600-100	600-125	600-160
Kolben-Ø	(mm)	16	25	32	40	50	63	80	100	125	160
Stangen-Ø	(mm)	10	16	20	25	32	40	50	63	80	100
Druckkraft pro 100 bar	(kN)	2,0	4,9	8,0	12,6	19,6	31,2	50,3	78,6	122,7	201,0
Zugkraft pro 100 bar	(kN)	1,2	2,9	4,9	7,7	11,6	18,6	30,6	47,4	72,4	122,5
a	(mm)	60	65	75	85	100	125	160	200	230	300
b	(mm)	35	45	55	63	75	95	120	150	180	230
c	(mm)	40	50	55	63	76	95	120	158	180	230
d	(mm)	22	30	35	40	45	65	80	108	130	160
e ab Hub 3	(mm)	25	26	27	27	30	41	-	-	-	-
f	(mm)	30	33	38	40	44	50	60	64	82	90
g	(mm)	6,5	8,5	10,5	10,5	13	17	21	25	32	39
o		M6x12	M10x15	M12x15	M16x25	M20x30	M27x40	M30x40	M42x60	M48x70	M56x80
SW	(mm)	8	13	17	22	27	36	46	55	70	90
i		G1/4	G1/4	G1/4	G1/4	G1/4	G1/2	G1/2	G1/2	G1/2	G1/2
h1	(mm)	13	12	12	12	12	17	20	18	29	32
h2	(mm)	18	20	23	25	27	28	36	39	50	54
L1	(mm)	40	44	50	54	65	72	85	90	110	128
L2	(mm)	6	7	10	10	10	14	14	15	16	22
Masse Hub »0« (kg)		0,55	0,81	1,26	1,87	3,18	5,36	10,36	17,19	28,53	56,82
Gewichtszunahme pro 10 mm Hub (kg)		0,14	0,19	0,25	0,33	0,44	0,69	1,16	1,83	2,43	4,08

Hubvarianten für		600-016	600-025	600-032	600-040	600-050	600-063	600-080	600-100	600-125	600-160
Hub 1	(mm)	16	20	25	25	25	30	32	40	40	40
Hub 2	(mm)	50	50	50	50	50	63	80	100	100	100
Hub 3	(mm)	100	100	100	100	100	100				

Bestell- Grundbezeichnung + Hub in mm = Bestellnummer
beispiel: 600-050 + 025 = 600-050-025